



# Digi E Mill 5



5  
Axes

1  
Disc

6  
Blocks

17  
Tools

Dry

Milling

CAM  
Software  
incl.

**Made in Germany**  
100% developed and manufactured in Germany

Freedom from compressed air thanks to innovative AIRTOOLS



Neither an external compressed air connection nor a built-in compressor is required for the Digi E Mill5. This is made possible by the **AIRTOOL**, which is also patent pending.

The turbine blades of the AIRTOOL generate a strong air flow due to the high speeds of the high-frequency spindle, which keeps the workpiece free of chips and dust. These are removed by the suction system.

Available for: **composites** / **pmma, wax** / **zircon**

# Digi E Mill 5

## einfache Installation

Simple installation via LAN and CAD/CAM software  
- no calibration necessary!

- environmentally friendly shipping possible due to the low machine weight
- Free choice of location - thanks to freedom from compressed air

**Plug & Mill: unpack, switch on, start milling!**

## Start / Stop button

Integrated start button (touch sensor) enables quick start/stop of ongoing milling operations.

- Easy handling for the end user

## Compact design

- Generously dimensioned workspace
- convenient clamping of the workpieces or loading of the automatic tool changer

## automatic tool changer

- Space for 16 standard tools plus an AIRTOOL
- Length measurement and tool breakage control via precision measuring probe

## Usable materials

Composites, plastic/wax, zirconium, CoCr sintered metal  
**No metal - only sintered CoCr possible!**

- Circular blanks, thickness 10-40 mm,  
- Diameter 98.5 mm  
- Diameter 110 mm (requires optionally available holder)
- Blocks up to 40 × 20 × 20 mm  
(requires optionally available block holder)

## Indications

Crowns, bridges, inlays, onlays, veneers, occlusal splints, full dentures, denture frameworks, implant bars, abutments, screw retained crowns, screw retained bridges, surgery guides, primary crowns, secondary crowns, model plates, model tooth dies



## Service-optimized machine concept

- reduced service effort - easy maintenance also possible by end customers
- **no service technician, the customer can do everything himself**
- In case of emergency, important components such as the spindle and control unit can be easily replaced by the operator in a few simple steps
- No more special tools required, everything child's play

## effective / economical

- **up to 30% savings in** for the machining of blanks
- Millable up to the outer edge of the blank due to special clamping system
- **Sustainable operation**, as no compressed air is required

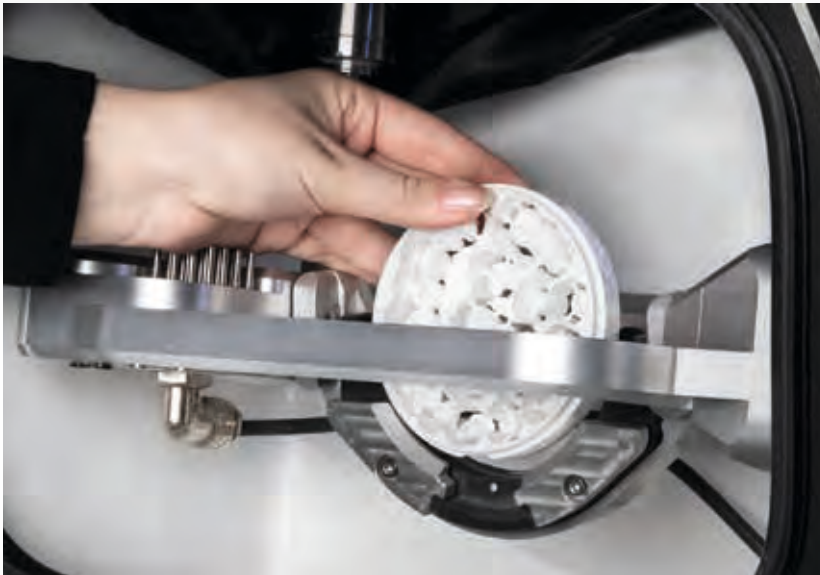

## flexible

- mills almost all materials up to CoCr sintered metals in 98.5 mm round format
- optional: holder for **110 mm discs**
- optional: holder for **blocks** - for up to 6 blocks of different sizes
- maximum indication variety due to  $\pm 35^\circ$  rotation angle in the 5th axis and **blanks up to 40 mm thickness**
- DENTALCAM software **with open interface** to all scanners and materials

## fast & precise

- 800 watt spindle with 60,000 rpm
- 3  $\mu$ m Repeatability
- Cast aluminum body for low vibration operation

### Big time saver:

- 50% faster data import (nesting)
- Improved milling times:- Crown milling in less than 10 minute

# Digi E Mill 5

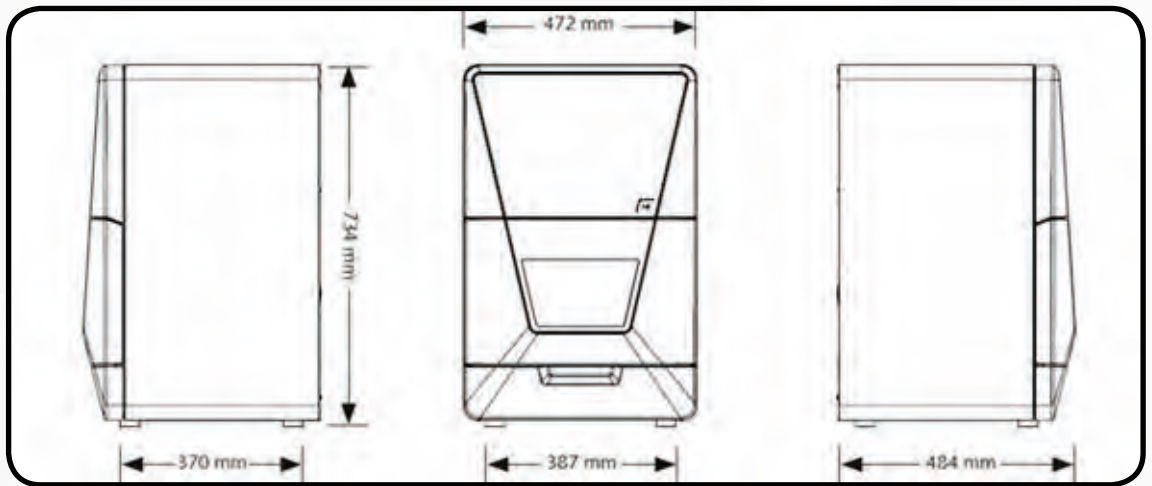

Service package Digi E Mill 5 - inclusive

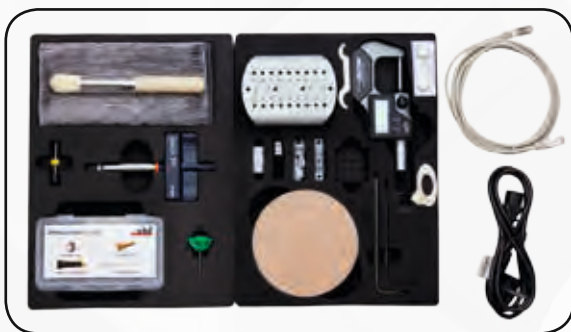

optional: tool set initial equipment Digi E Mill 5  
Art. 481-5011



# Digi E Mill 4

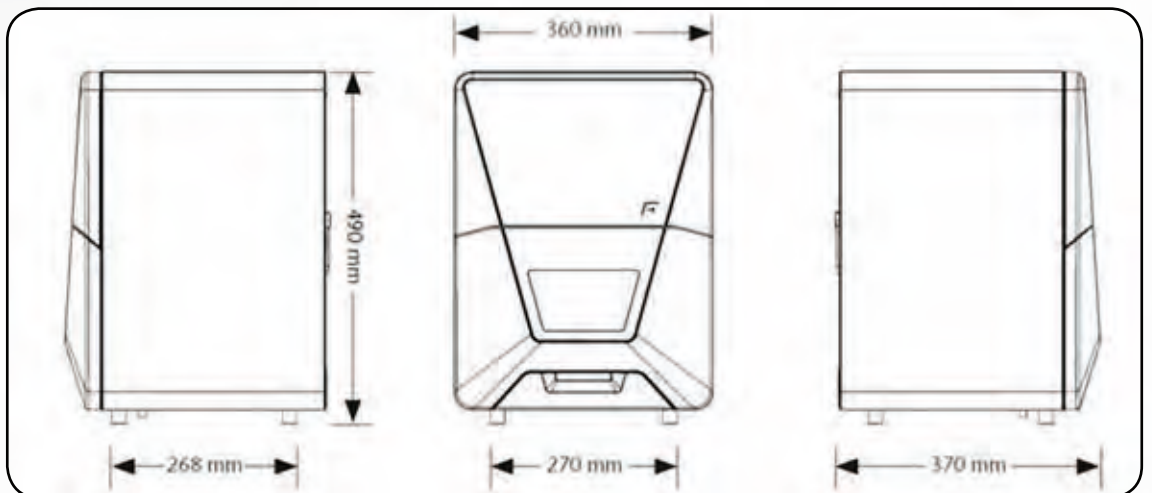

Service package Digi E Mill 4 - inclusive



	<b>Digi E Mill 5</b>	<b>Digi E Mill 4</b>
<b>GENERAL</b>	Art. 481-5010	Art. 481-4010
Areas of application	Dry machining	Wet/dry machining
Materials	Composites, plastics/wax, zirconia, CoCr sintered metals • Discs, height 10–40 mm, diameter 98.5 mm • Blocks up to 40 × 20 × 20 mm (block holder required)	Composites, plastics/wax, glass ceramics, zirconia • Blocks up to 45 × 20 × 20 mm
Indications	Crowns, bridges, inlays, onlays, veneers, occlusal splints, full dentures, denture frameworks, implant bars, abutments, screw retained crowns, screw retained bridges, surgery guides, primary crowns, secondary crowns, model plates, model tooth dies	Crowns, bridges, inlays, onlays, veneers, zirconia abutments, Screw-retained crowns
Holder systems	Halterung für 98,5-mm-Ronden (integriert) • Halterung für 110-mm-Ronden (optional) • Blockhalter (optional) • Ivotion1 Zubehör-Kit (optional)	Integrated block holder
Number of axes	5	4
Rotary axis	rotation angle: 360° (A-axis), ±35° (B-axis)	rotation angle: +190° to -10° (A-axis)
Lighting	RGB LED lighting with status indication	
<b>SPINDLE</b>	High-frequency spindle with electromechanical tool change Up to 60,000 rpm	
Collet	For tools with 3 mm shank diameter and max. 40 mm total length (Compatible with the previous tools)	
Power	Peak power (Pmax): 800 watts · nominal power (S6): 400 watts · continuous power (S1): 300 watts	
Tool change	Tool magazine for 16 tools plus one AIRTOOL	Removable tool magazine for 6 tools with additional space for one AIRTOOL
	length measurement and tool breakage monitoring via precision measuring key · access via front-door, safety-locked	
<b>PROCESSING MODES</b>		
Wet	-	2 fluid nozzles on the spindle · integrated cooling liquid tank · PUREWATER Technology: no grinding additives required
Dry	Compressed air-free operation through use of AIRTOOLS · hose connection for external suction unit on the back of the housing · 24 V switch output for controlling suction units	Compressed air-free operation through use of AIRTOOLS · hose connection for external suction unit on the back of the housing · 24 V switch output for controlling suction units · optional dry container required
<b>CONNECTION REQUIREMENTS</b>		
Compressed air	-	
Power supply	100–240 volts · 50/60 Hz, 500 watts	
Extraction system	Extraction filter class M, 2,500 l/min extraction capacity at 200 hPa	
<b>ENVIROMENTAL CONDITIONS</b>		
Operating temperature	Between 10 °C and 35 °C	
Air moisture	Max. 80 % (relative), non-condensing	
<b>DIMENSIONS &amp; WEIGHTS</b>		
Dimensions (W/D/H)	472 × 484 × 734 mm with closed door 472 × 567 × 734 mm with open door	360 × 370 × 490 mm with closed door 360 × 420 × 490 mm with open door
Weight	43 kg	28 kg
<b>SCOPE OF DELIVERY</b>		
CAM Software	DENTALCAM software included	
Subject to changes and errors		

# Digi E Mill 4



4  
Axes

0  
Discs

1  
Blocks

7  
Tools

Wet  
Dry

Grinding  
Milling

CAM  
Software  
incl.

**Made in Germany**  
100% developed and manufactured in Germany



Freedom from compressed air thanks to innovative AIRTOOLS

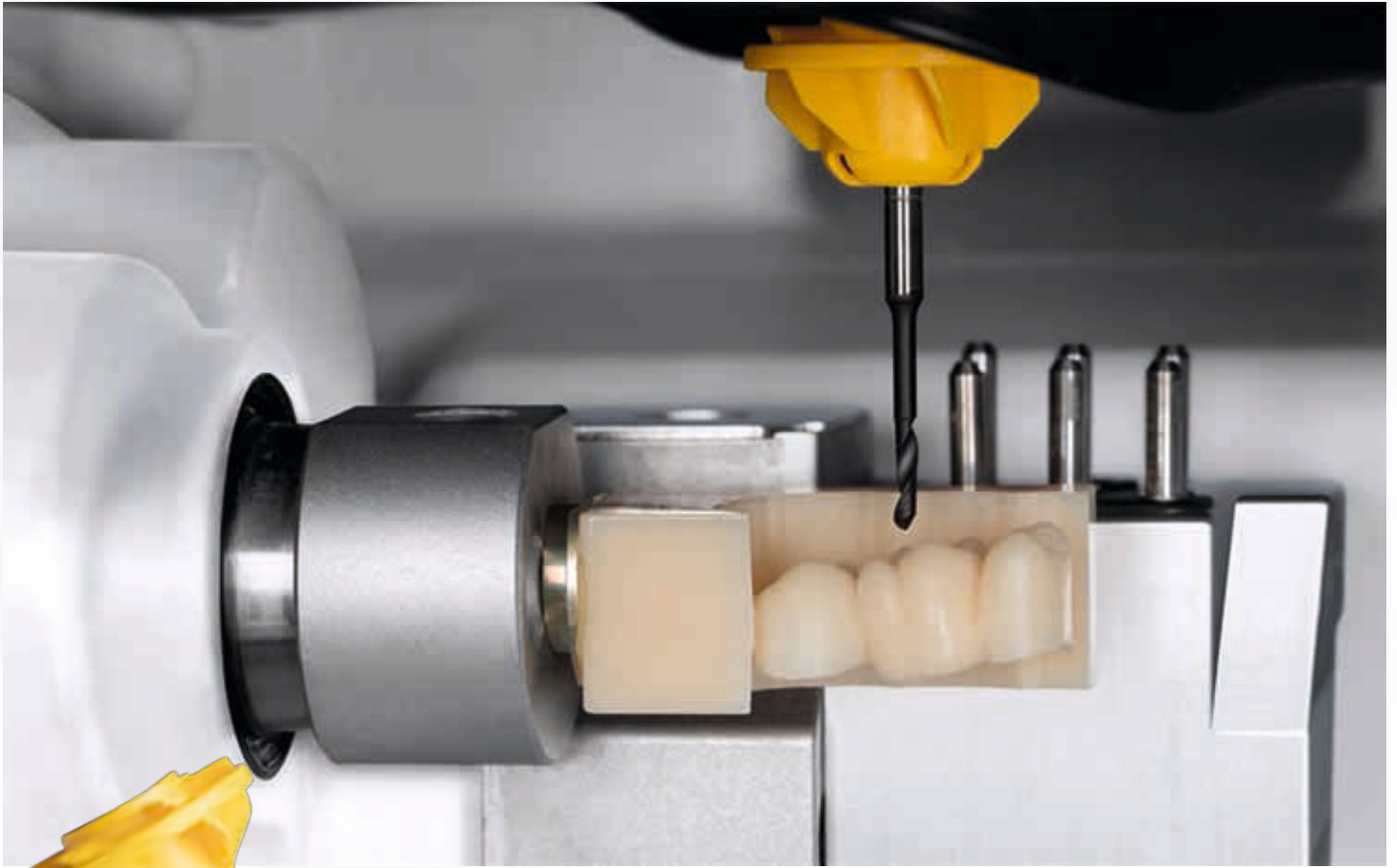

The Digi E Mill4 requires neither an external compressed air connection nor a built-in compressor. This is made possible by the **AIRTOOL**, which is also patent pending.

The turbine blades of the AIRTOOL generate a strong air flow due to the high speeds of the high-frequency spindle, which keeps the workpiece free of chips and dust. These are removed by the suction system.

Available for: **composites** / **pmma, wax** / **zircon**

# Digi E Mill 4

## einfache Installation

Simple installation via LAN and CAD/CAM software  
- no calibration necessary!

- environmentally friendly shipping possible due to the low machine weight
- Free choice of location - thanks to freedom from compressed air

**Plug & Mill: unpack, switch on, start milling!**

## Start / Stop button

Integrated start button (touch sensor) enables quick start/stop of ongoing milling operations.

- Easy handling for the end user



## Tool change

- Removable tool magazine for 6 tools with additional individual space for an AIRTOOL
- Length measurement and tool breakage control via precision measuring probe



## Usable materials

Composites, plastic/wax, glass ceramic, zirconium  
- grinds and mills almost all block materials up to 45 mm

after inserting the tank for wet processing

**wet:** glass-ceramics or composites with ceramic content

with optionally available container for dry machining

**dry:** Zircon, PMMA and Wax

## Indications

Crowns, bridges, inlays, onlays, veneers, zirconium abutments,  
screw-retained crowns



## Service-optimized machine concept

- reduced service effort - easy maintenance also possible by end customers
- **no service technician, the customer can do everything himself**
- In case of emergency, important components such as the spindle can be easily replaced by the operator in a few simple steps
- No more special tools required, everything child's play

## Wet grinding

Insert the tank for wet processing.

- **PUREWATER technology**  
no abrasive additives for coolant necessary

- 2 liquid nozzles on the spindle
- integrated reservoir for coolant

Machining of block materials from:

Glass ceramics or composites with ceramic content



## Dry milling

Insert the optional container for dry processing.  
A special filter mat in the liquid tank ensures that the tank is chip-free.

Compressed air free operation by using AIRTOOLS Machining

of block materials from:  
Zirconia, PMMA and various composites



## innovative

Combination compartment for coolant reservoir or optional dry reservoir

## fast & precise

- 800 watt spindle with 60,000 rpm
- 3  $\mu$ m Repeatability
- sturdy aluminum construction

## Same-Day-Dentistry

From the intraoral scanner to the perfect dental restoration, which can be used practically without rework.

- fast treatment in just one session.



**innovative**  
**clever**  
**user-friendly**



**Made in Germany**

100% developed and manufactured in Germany